

Content Development Process

Sydney, October 2011

Jane Millar - Chief Quality Officer, Co-chair Collaborative Editing Project group

Ian Green - Co-chair Collaborative Editing Project group

Dr Kent Spackman – Chief Terminologist



What is it ?

- The SNOMED CT Content Development Process is a key building block for the IHTSDO to develop a future quality assured comprehensive clinical terminology.
- This process will introduce and support SNOMED CT editing from different sources, levels of editor, varied tooling etc
- The development process will be designed to meet the current, and future needs of the IHTSDO
- Defining the processes for supporting and managing editing contributions to the International Release in the context of 'Collaborative Editing'
- For Collaborative Editing it is essential to have in place a clearly defined end to end Content Development Process



The content development process





Why we are doing this ?

- Requirement highlighted by the Chief Terminologist and the Content Committee
- An increase in the number of users of SNOMED CT
- An increase in demand for change
- Increased levels of content quality assurance required by users and the IHTSDO
- A drive to collaborate with the clinical community world-wide on current and future content development/changes
- A need to streamline the content development process itself to enable it to be more responsive to requesters and responsive to increasing volume of change requests.



Strategic goals

IHTSDO Strategic Direction to 2015:

A sound and valued primary product [SNOMED CT] and a range of secondary products [e.g. maps and guides] that:

- Are preferred and wanted by policy makers, clinicians and health & social care organisations
- Are maintained and improved by a system with more capacity and capability
- Are managed by a responsive organisation
- Are funded in a financially sustainable manner that best serves citizens and Members
- Are quality assured from not only a technical but also a clinical governance Perspective



Strategic priorities

Strategic Priorities and Initiatives to October 2012:

Strategic Priority 2 - Produce robust terminology standards that are “fit for purpose” for priority use cases

a. Update and quality assure the International Release of SNOMED CT at least two times per year

ACCOUNTABILITY TARGET: Produce and quality assure at least two updates to the SNOMED CT International Release per year based on agreed priorities for quality enhancement of existing and expanded content in line with plans developed by the Content Committee (2010-2012)

SHARED GOAL: Growth in SNOMED CT translations that adhere to IHTSDO translation guidelines or standards

b. Increase involvement of the Community of Practice in the development and maintenance of SNOMED CT

ACCOUNTABILITY TARGET: Mechanisms for collaborative editing using the IHTSDO Workbench in place and being tested by the end of 2012

SHARED GOAL: Strong global community of qualified editors contributing to International Release of SNOMED CT through collaborative editing by the end of 2015



Who is doing this ?

- The IHTSDO is committed to developing a more responsive process
- Management Board assigned project responsibility to Chief Terminologist and Chief Quality Officer
- Collaborative Editing Group
- Project Steering Committee formed
 - Jane Millar (Chief Quality Officer, Co-Chair, Collaborative Editing Project Group)
 - Kent Spackman (Chief Terminologist)
 - Gwen Smith (Chair, Request Submission Project Group)
 - Ian Green (Co-Chair, Collaborative Editing Project Group)



What is the project scope ?

- Broad Scope includes
 - Define processes to develop and enhance content
 - Define process guidance for terminology authors
 - Information technology infrastructure to support the processes and to store and serve content development process
 - Publication methods and processes
 - Training and certification programs for terminology authors
 - A resource registry for content development resources
- Initially the project has focused on agreeing the scope, defining and documenting a draft process and identifying use case and technical requirements



How does this fit with other activities?

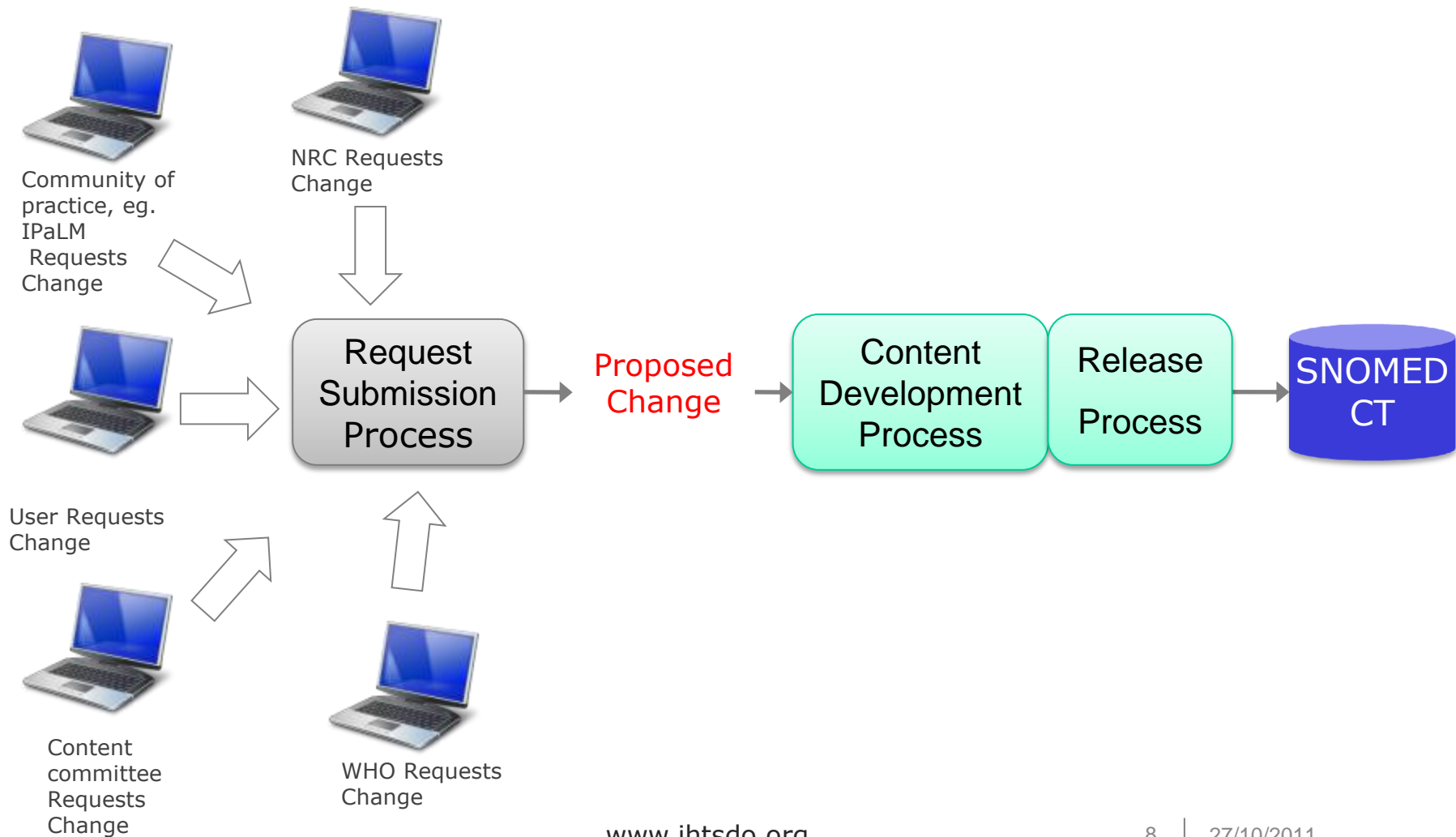



What is the timeline?

- Project initiation : July 11, 2011
- Design: July – October 2011
- Collect Feedback: October 2011
- Prototyping: November 2011 – February 2012
- Trials: 2nd Quarter 2012
- Implementation: 3rd Quarter 2012



What has been done so far?

- Scope statement for the project
- Process description documentation
- Phase 1 : Creation of a content development process design
 - Identify use cases
 - Identity high level requirements
 - Identification and description of the tasks involved
 - Sequencing of the tasks in the process
 - Identify interactions and dependencies with other activities



What happens next?

- Collect feedback on the proposed design
 - Starts now How do we do it ?
- Update design/process description as necessary
- Create a prototype to get experience with workflow and finalize the data models
- Detailed design of interfaces with other projects
 - Request submission process
 - IHTSDO workbench



Scope document

- Introduction
- Business Objectives
- Product Description
- Project Environment
- Project Scope
- Deliverables
- Roles and Team
- Project Management Approach
- Schedule



Process Flow Overview

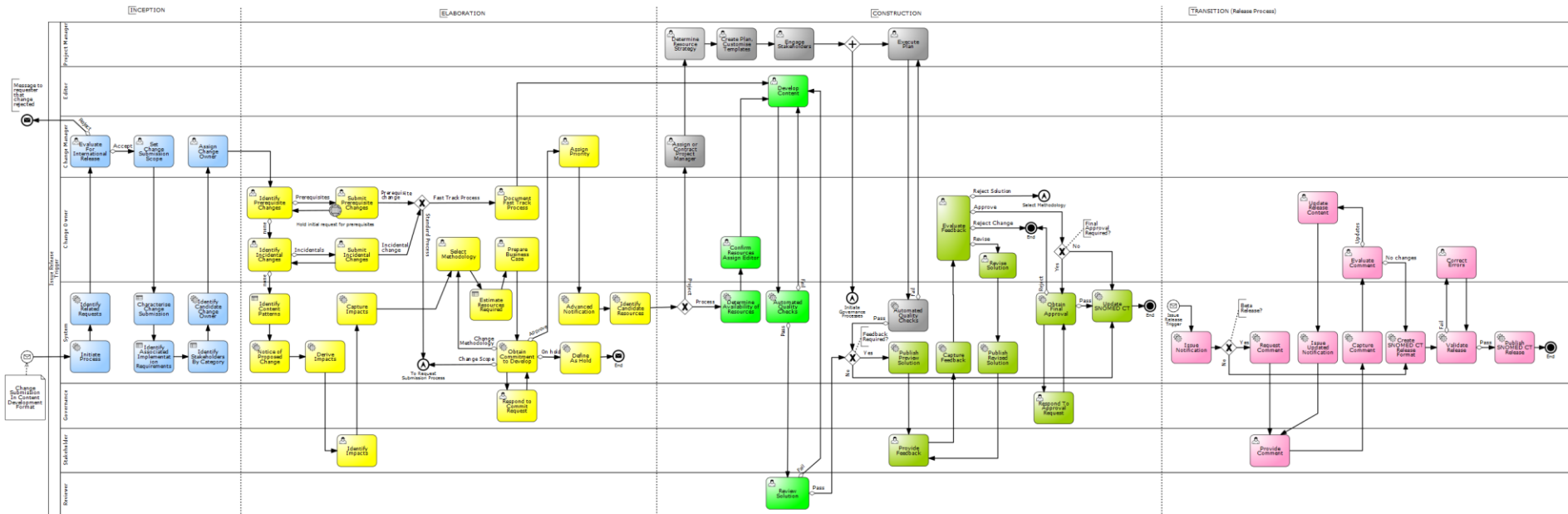

We will take this in pieces, one sub-process at a time



Process Overview

- Agenda
 - Characterization
 - Methodologies
 - Roles
 - High level process flow (sequencing of sub-processes)
 - Mapping to Open Unified Process (OUP) methodology



Characterization

- The nature of proposed changes varies from simply correcting spelling mistakes to developing entire new branches within SNOMED CT model
- The process is designed to adapt dynamically to the nature of change being considered based on the characterization of the proposed change
- Characterization has been defined along four axes initially (more may be required)
 - **Scope:** change to the model, a concept, or to policy (a rule, template or other expression of policy)
 - **Modification** (nature of change; modify, extend, create, etc.)
 - **Quantification** (is a single instance involved or multiple instances)
 - **Component** (is this a change to a definition, a relationship, a classification, etc.)



Methodologies

- Based on the characterization of the change, one of two methodologies will be used to develop the content
 - Process methodology: the content development work is assigned to a terminologist as a task in the process
 - Project methodology: a project team will be assembled under the direction of a project manager. The team will apply OUP project methodologies to develop the required content
- Fast Track
 - To support use cases where a terminologist has indentified a minor change that must occur prior to addressing the current change request, the process envisages a fast track which allows a change to undertaken without the requirement for full formalization, feedback and notification phases of the standard process



Roles

Role ID	Assigned By	Functions
Change Manager	IHTSDO	<ul style="list-style-type: none"> • Oversight of all content development processing
Change Owner	Change Manager	<ul style="list-style-type: none"> • Oversight of processing of a specific content change • Manages exceptions • Identifies resources and assigns Project Manager or Editor • Reviews the evaluation of content change requests and makes a determination as to whether to process the request
Requestor	self	<ul style="list-style-type: none"> • Formulates the content change request • Responds to requests for clarification • Provides feedback to proposed solutions
Stakeholder	self	<ul style="list-style-type: none"> • A generic role to represent anyone interested in a change, there are many types of stakeholder
Governance	self	<ul style="list-style-type: none"> • Approves changes
Editor	Change Owner	<ul style="list-style-type: none"> • Develops the content solution
Reviewer	Change Owner / Editor	<ul style="list-style-type: none"> • Reviews proposed solutions before publication for broader comment.
Project Manager	Change Manager	<ul style="list-style-type: none"> • Manages a project for those content changes that warrant it



High Level Process Flow

- Once the proposed change has been characterised and accepted for development, the process bifurcates to create the content, using either a project management methodology (Build Solution) or simply assigning the work to a terminologist (Develop Content)
- Processing then comes back together for feedback, notification and release.

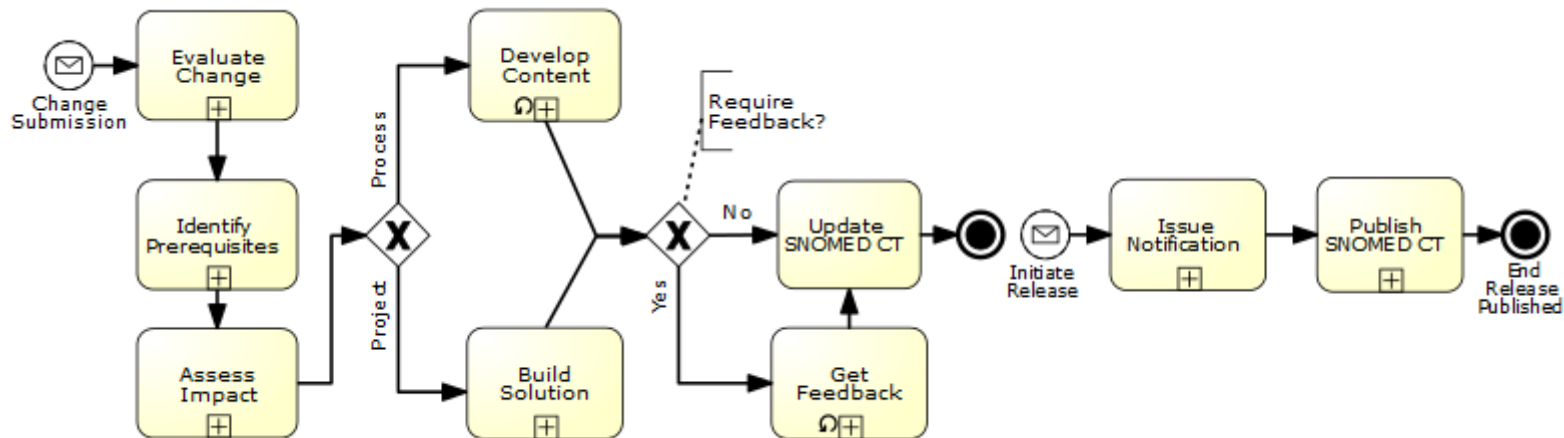

Each of the above is a sub-process, details of each follow



Mapping to OpenUp

OpenUp Phase	Sub-process	Outcome
Inception	Evaluate Change	A determination if the proposed change is in scope for the international release and the initial scale of the proposed change.
Elaboration	Assess Impact	Approval obtained to commit resources to develop a solution using a selected methodology.
Construction	Manage Project	A proposed solution developed using a project methodology.
	Develop Content	A proposed solution developed by an Editor assigned to create content in response to a request.
	Get Feedback	Community feedback has been collected, reviewed, and acted on as appropriate.
Transition	Issue Notification	Community has been advised of proposed changes to SNOMED CT.
	Publish SNOMED CT	New SNOMED CT release is available



Process Flow

- Agenda: sub-processes
 - Evaluate Change
 - Identify Prerequisites
 - Assess Impact and Commit to Develop Content
 - Manage Process (project methodology)
 - Develop Content (process methodology)
 - Get Feedback
 - Issue Notification
 - Publish SNOMED CT



Health Warning

- The proposed process is the “generic” version and tooling independent
- The software implementation of the process will support more than one variant of the process
 - Two are shown today; standard and fast track
- There may be many different processes in operation at the same time for different scenarios and purposes
 - For example, the process to define a new content pattern, or a new constraint in the SNOMED CT model may vary in some details from the process to expand a branch of SNOMED CT



Evaluate Change (Inception)

- End state: Proposed change is characterized and confirmed with an agreed set of change information

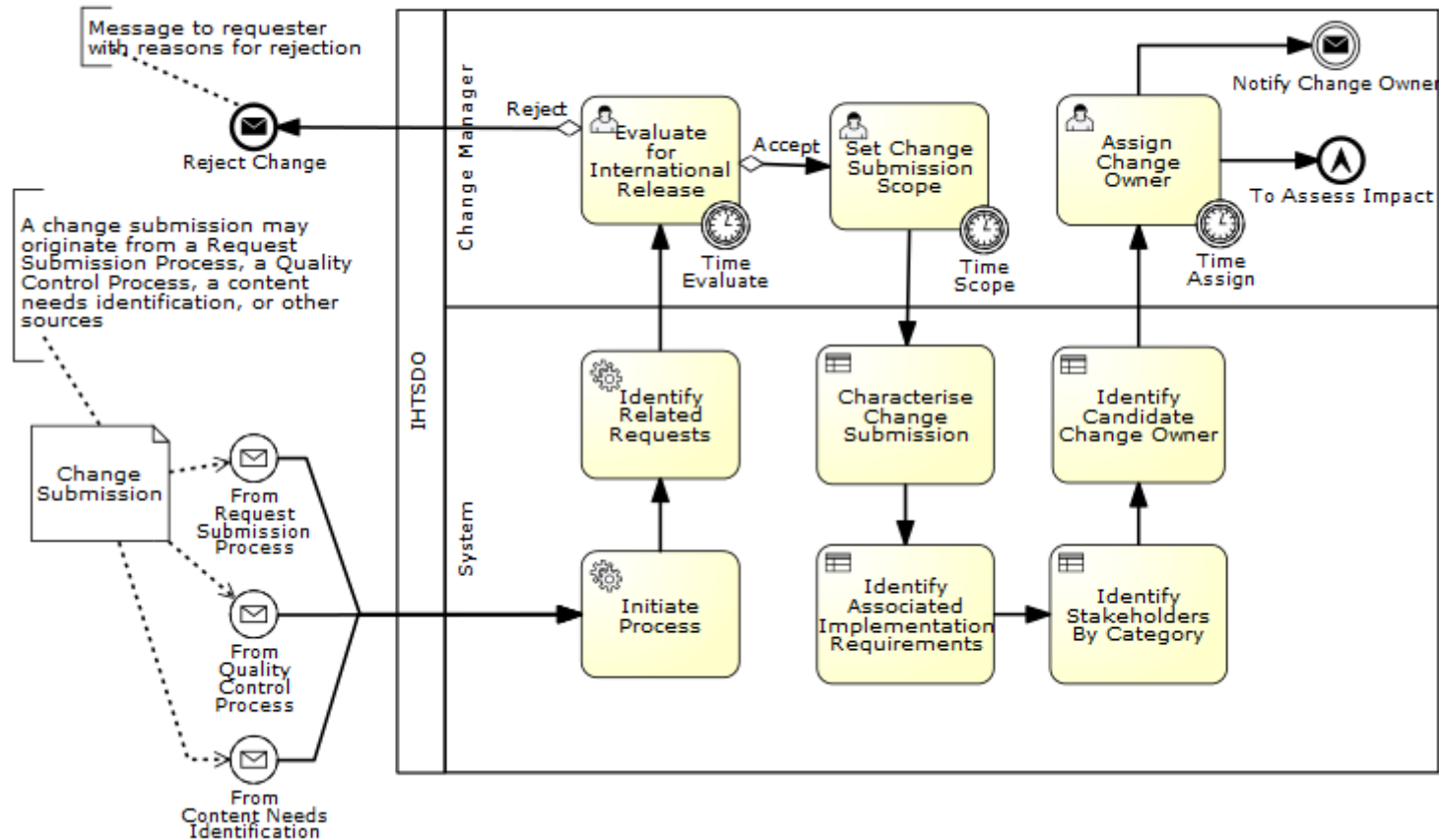



Elaboration

- End state: commitment to editing the proposed content

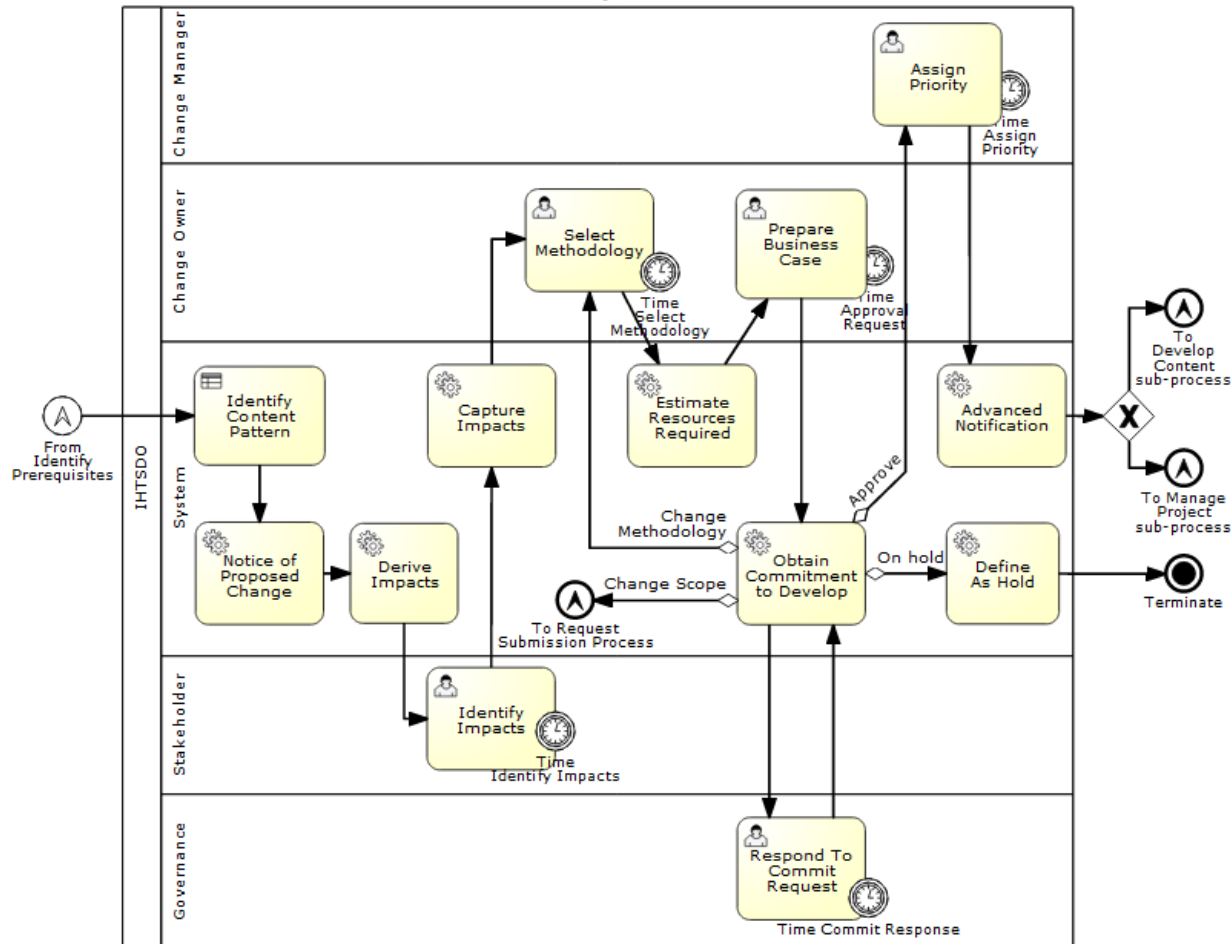



Construction (project methodology)

- End state: content has been created

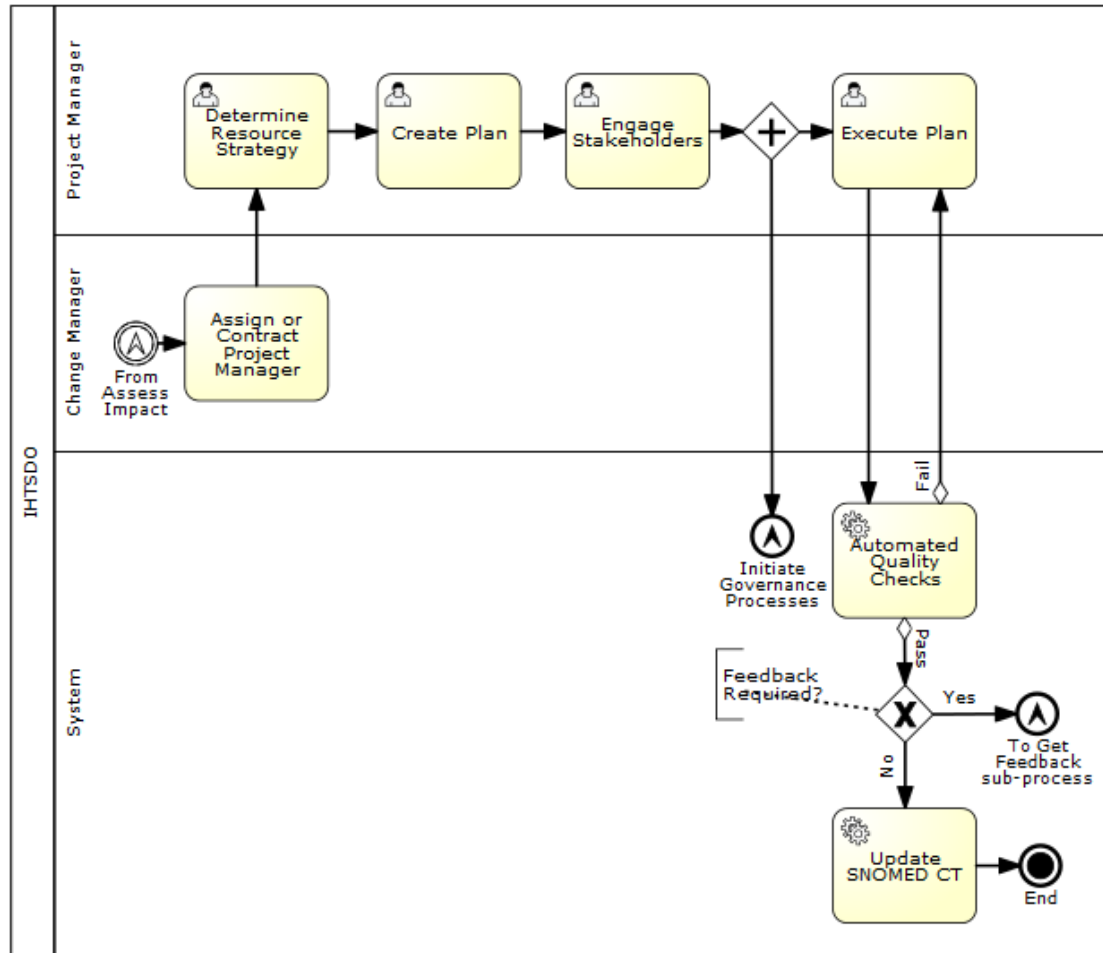



Construction – fast track

- End state: content has been created

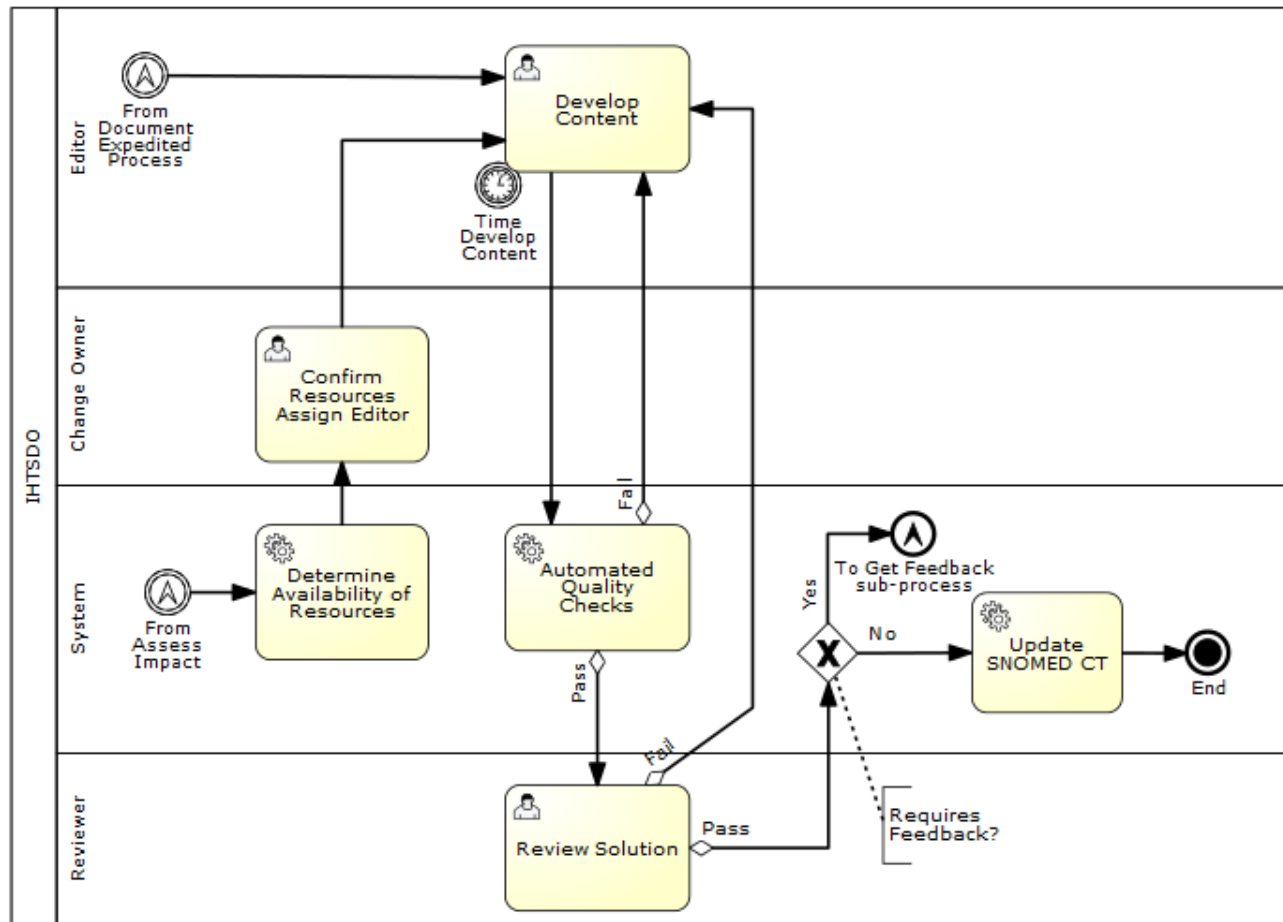



Transition

- End state: feedback has been collected, evaluated and acted on. Final approval, if necessary has been obtained. Publish change.

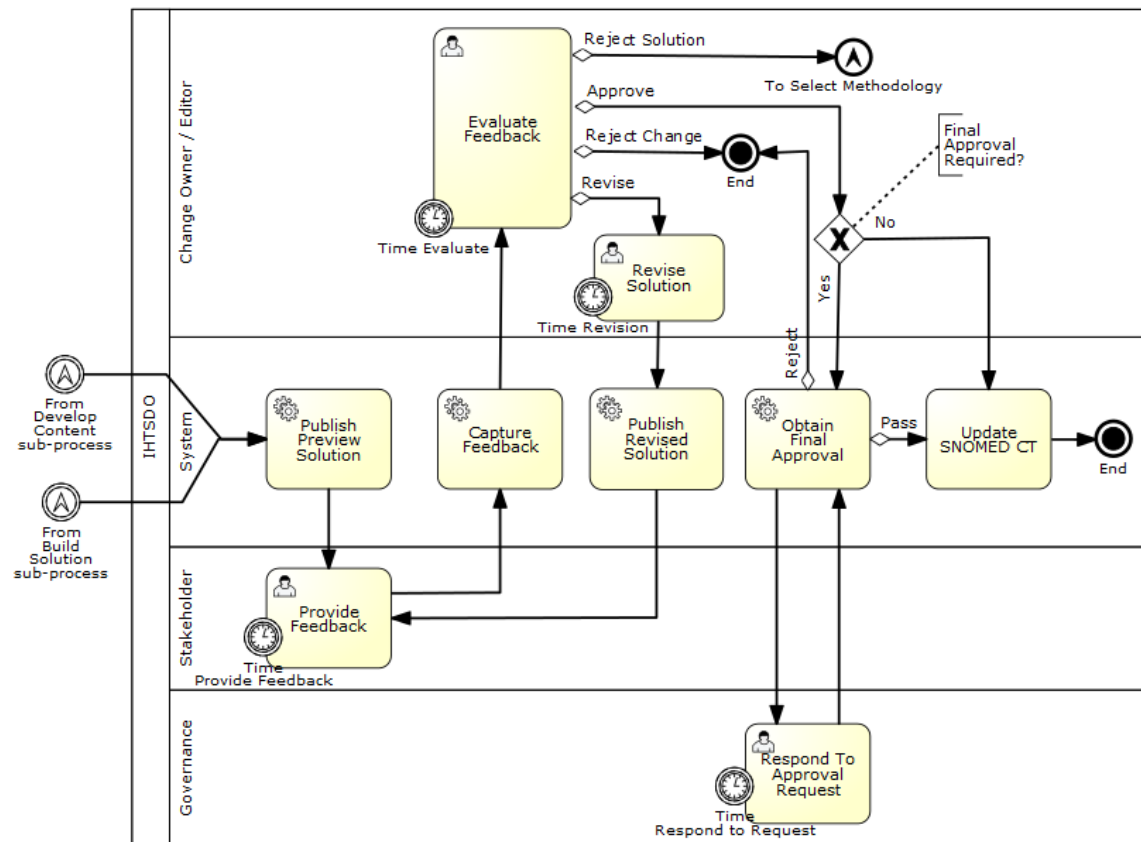



Issue notification

- End state: community has been advised of the proposed changes

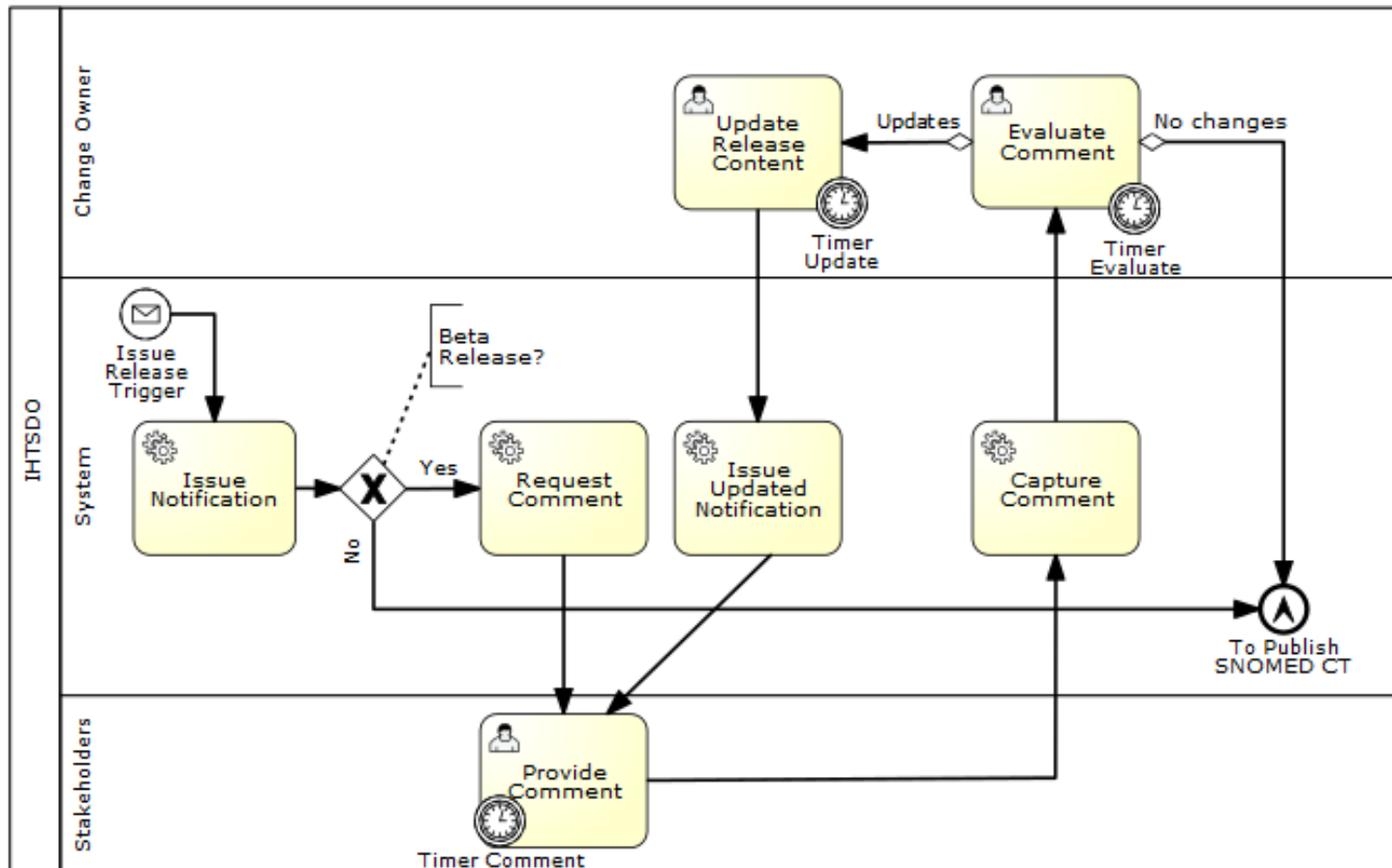



Publish SNOMED CT, part of transition phase

- End state: the new International Release is available

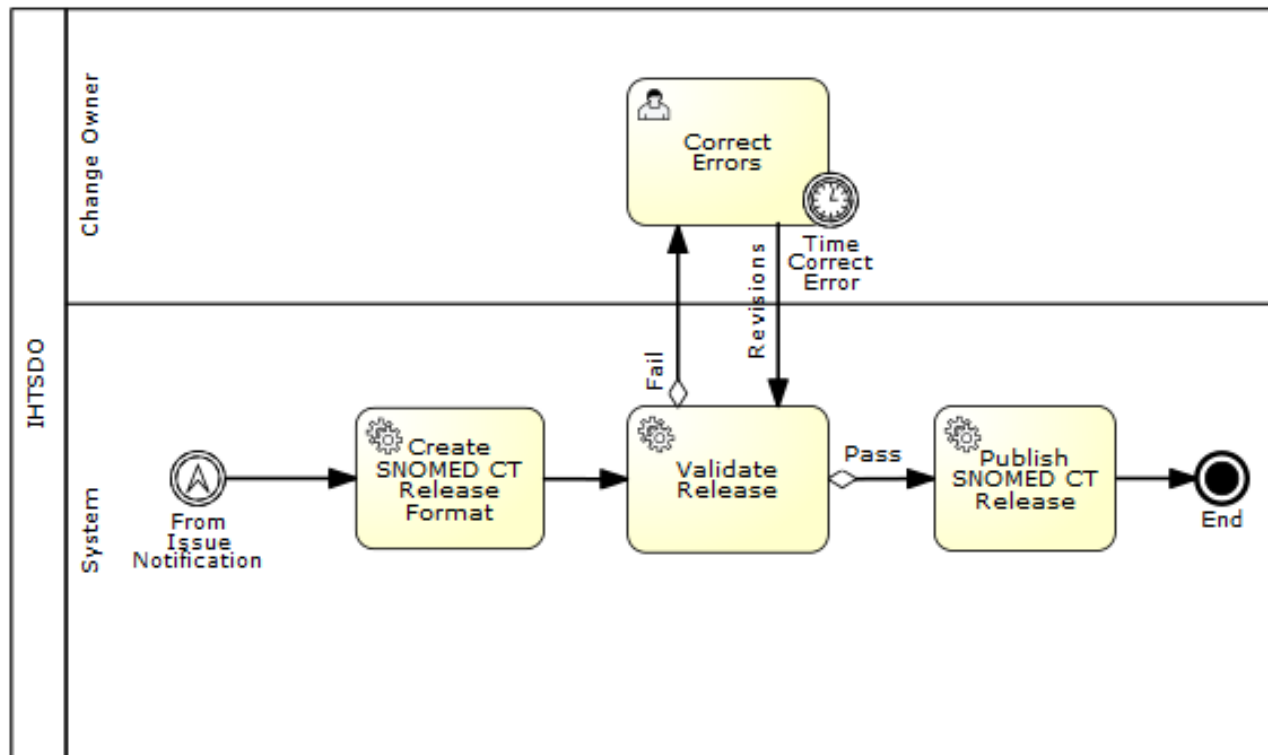



Fast Track Process

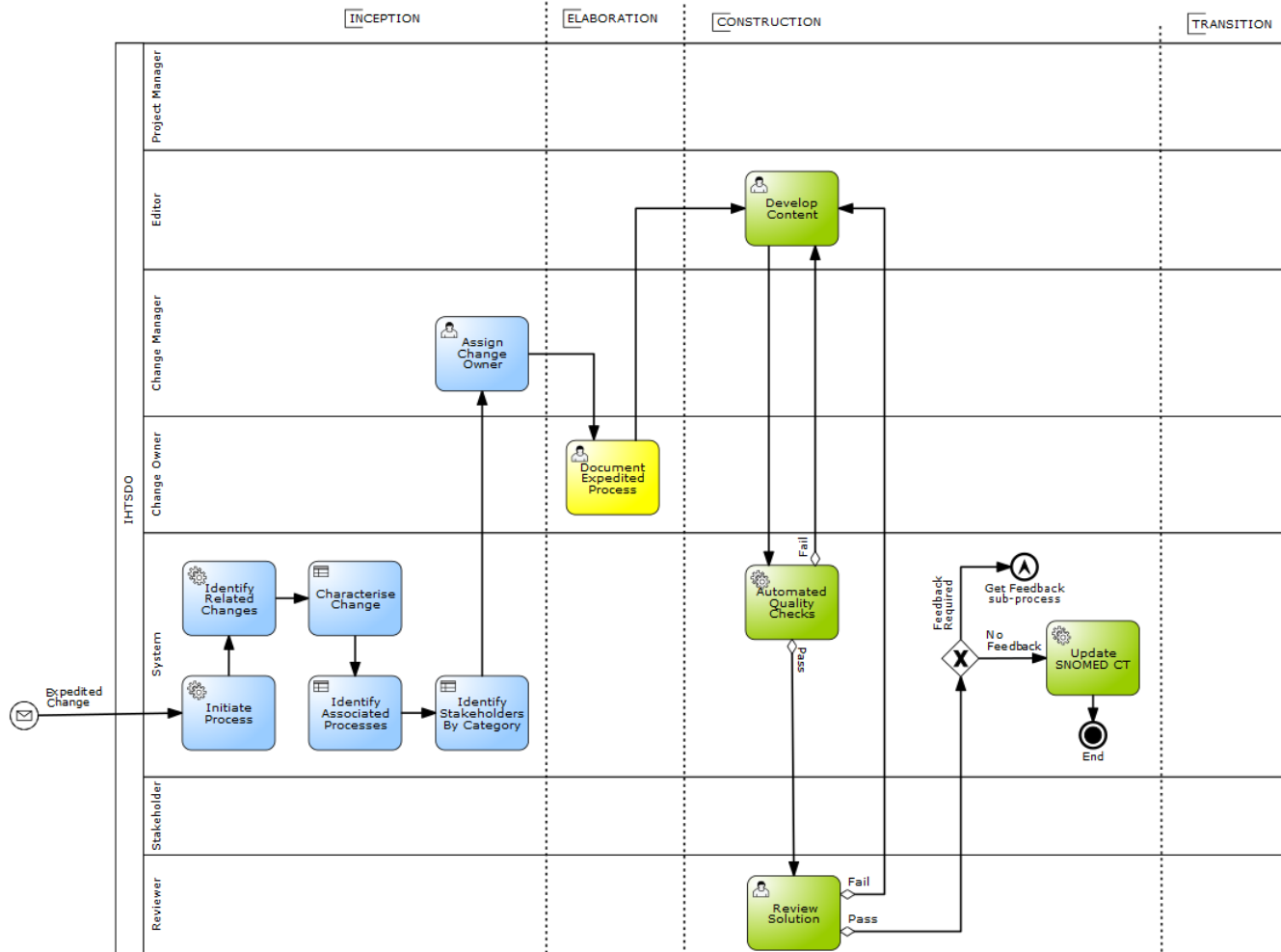



Dependencies on Other Projects

- Development Process implementation will require cooperation with other projects on which it has dependencies
 - Request Submission Process
 - . . . ?
- Process as designed assumes the availability of additional resources
 - Resource Registry
 - Training and Certification program
- Initially the Content Development Process work can begin to be implemented without a number of these being in place



Work Remaining on Process Design

- Finalize hand-off between Request Submission Process and Content Development Process
 - Agree detailed information requirements for the Request Submission process to pass to Content Development process
- Agree form of Guidance Framework
 - Process design proposes guidance framework , a rules based system
 - Guidance expressed as rules
 - Guidance is machine interpretable and enforceable
 - Include templates, content patterns
 - End to end guidance documentation



Next Steps

- Implementation and link to both Collaborative Editing and Request Submission work
- Iterative amendments based on usage
- Working with IHTSDO Consultant Terminologists and Senior Terminologist
- Using the draft content development process agreed by the Collaborative Editing project group
- Create draft detailed process and implementation guidance
- Development of draft templates
- Create a prototype/mock-up of workflow process with some user interfaces to enable trialing the process
- Whilst being tooling agnostic, need to evaluate and manage any interfaces with IHTSDO workbench



Focusing on 'construction' and collaborative editing

- Phasing of implementation linking to collaborative editing and the processes required to move from individuals using the IHTSDO workbench to edit the International release to multiple
- Adaptation of existing work flow where possible and requirements for longer term changes
- 'Certification' of editors i.e. levels of operation and responsibility
- Management of any 'bottlenecks' in the process
- Meeting Management Board requirement to have 10 terminology editors using the IHTSDO workbench by July 2012
- Confirmation of revised steering group

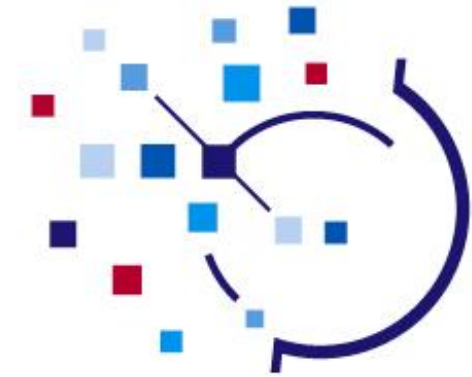

Content Development Process

Sydney, October 2011

Jane Millar - Chief Quality Officer, Co-chair Collaborative Editing Project group
Ian Green - Co-chair Collaborative Editing Project group